

ACCESS ELEVATOR LTD.

Call Us Today 631.694.4400

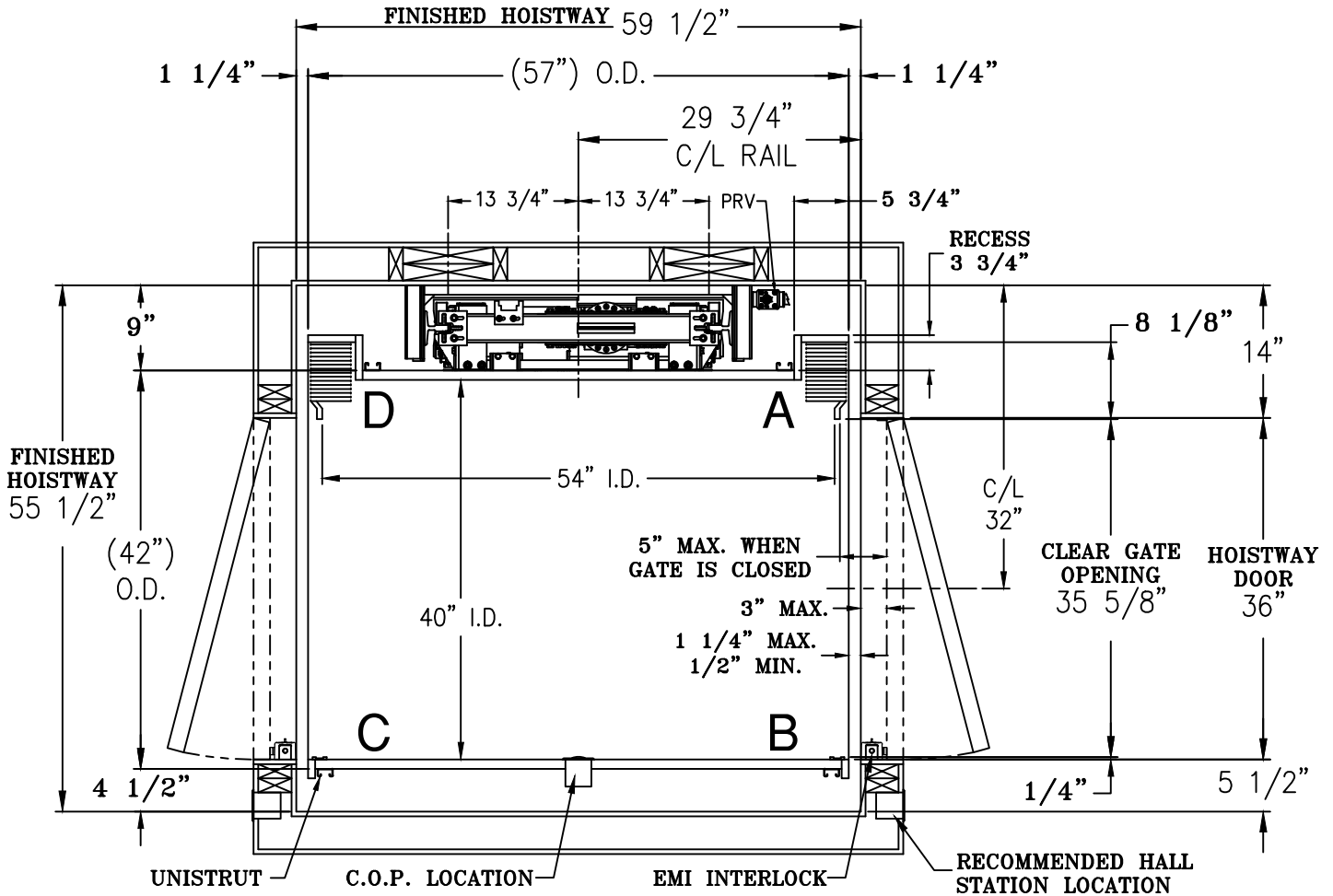

REV. C



DIMENSIONS ARE IDENTICAL PER SIDE UNLESS NOTED.

Dave Russo
Access Elevator, Ltd

www.accessellevatorltd.com

94 Verdi Street
Farmingdale, NY 11735
631-694-4400 ph
631-454-6311 fax

david@accessellevatorltd.com

- 1) HOISTWAY BY OTHERS PER CODE. WALLS TO BE PLUMB AND SQUARE. ALL HOISTWAY DOORS BY OTHERS PER CODE.
- 2) FINISHED HOISTWAY = ROUGH FRAMING + DRYWALL + PLASTER + PAINT.
- 3) 2 7/8" MINIMUM WIDTH REQUIRED TO MOUNT LOCK TO JAMB.



1726 North Ballard Road
Appleton, WI 54911
Phone: 800-238-8739

ELEVATOR CONTRACTOR:

JOB NAME:

ORDER NUMBER:

**EXCELEVATOR SERIES
HYDRAULIC ELEVATOR
ABR DCR OPENING W/ ACCORDION GATE**

DRAWN BY:

DATE:

SIGNATURE OF APPROVAL

DWG. NO.

C-002886